



**AGENDA FOR
PORT OF ILLAHEE COMMISSION
Wednesday, September 13TH - 6:30PM
ZOOM MEETING #715 0997 5823 / Password: Illahee**

1. CALL TO ORDER

2. CONSENT AGENDA

- 1. Agenda
- *2. The August 9th, 2023 Regular Meeting minutes
- Rupert *3. The July 31st 2023 All Ports Meeting Minutes
- *4. Pay Bills with check numbers **5077** through **5089** totaling **\$8,887.23**

3. SIGNING OF DOCUMENTS

Determine when/how to have at least 2 Commissioners sign the documents

4. PUBLIC COMMENT

5. REPORTS/UNFINISHED BUSINESS

Aho/ * 1. Grants/Waterfront Access Improvements

- Piccone
- Update of project permits and design
 - Meeting with the Tribe – Update of meeting
 - Status of the new BFP Grant application for piling replacement/other funding
 - Any update on the County's filtration project
 - DNR re-authorization of Ports aquatic lease agreement -status
 - John Piccone Project Status Summary

Aho 2. Illahee Store Project

- Septic design status
- PLIA Remediation

3. Treasurer's Report as of August 31, 2023 General Fund \$86,137.35 Investments \$ 284,985.26
Good Property Management (GPM) Account \$199.00 (total: \$371,321.61)

Rupert/Table 4. State Audit for January 2019 through December 2021

- Credit card resolution with RCW #

Aho /Table 5. Resolution 2023-4

- Interim Public Meeting Policy - status

Rupert 6. Illahee Days September 9, 2023

- Summary of event

7. Reports

Aho a. Website

- Anything to report?



**AGENDA FOR
PORT OF ILLAHEE COMMISSION
Wednesday, September 13TH - 6:30PM
ZOOM MEETING #715 0997 5823 / Password: Illahee**

5. REPORTS/UNFINISHED BUSINESS CONTINUED

Buesch

b. Properties

5560 Ocean View Boulevard/Rental

– Anything to report

5500 Illahee Road/Rental

– Anything to report

5507 Illahee Road/Illahee Store Property

– Anything to report

Illahee Road Lot

– Anything to report?

c. Dock/Pier

Rupert

– Anything to report

6. NEW BUSINESS

- *1. Budget Review – the 2024 Preliminary Budget will need to be approved next month with the final Budget being adopted during the November meeting.

7. PUBLIC COMMENT

- 8. ADJOURN** –Regular Meeting –October 11th @ 6:30PM – via ZOOM
- Kitsap All Ports---October 30th @ 6:30PM at Port of Brownsville
- Small Ports Seminar- October 26th & 27th at Campbell's Resort in Chelan, WA



Port of Illahee
Minutes of Regular Meeting
August 9, 2023

The Regular Port of Illahee meeting was held virtually through the ZOOM app (meeting id# 71509975823 / Password: Illahee). Notice of the virtual meeting was posted near the kiosk at the head of the pier and on the Port's website – portofillahee.com.

CALL TO ORDER

Commission Chairman James Aho called the meeting to order at 6:30 PM. Also, in attendance were Commissioner Jonathan Buesch; Commissioner Jeffrey Rupert; Administrator Jennifer Olson; Roy Barton; John Parvis and Janet Soderberg

CONSENT AGENDA

The following consent agenda items were approved: August Meeting Agenda; July 12, 2023 Meeting Minutes; checks numbering 5063 through 5076 totaling \$25,746.25 as outlined in the attached Voucher Approval (motion by Buesch; second by Rupert all in favor).

SIGNING OF DOCUMENTS

Commissioners plan to stop by the Port of Silverdale office to sign documents tomorrow.

PUBLIC COMMENT

A local community member asked, why are there barrels at the Illahee store?
Commissioner Aho responded that a contractor contracted thru PLIA needed to drill two more wells.

REPORTS/UNFINISHED BUSINESS - Commissioner Aho said that they are behind on approval for permits and still waiting on them.

Commissioner Aho reported that there is a meeting with the Suquamish tribe on August 31, 2023. Commissioner Buesch asked who was going to be at the meeting? Commissioner Aho replied, the Port's attorney, Commissioner Aho, John Piccone, the engineer on the waterfront improvement project and the attorneys for the tribe.

The Suquamish tribe is concerned about what will happen, when the Port replaces their fishing dock and pier, how will this affect the Geoduck harvesting? Commissioner Aho discussed he is going to bring reports that show that the Port replacing their dock and pier will have no to very little effect on Geoduck harvesting.



Commissioner Aho will have a discussion with John Piccone about the possibility of issuing bid requests during the winter season if the meeting with the tribe proves to be successful. Commissioner Buesch asked Commissioner Aho if he could contact the Port Administrator to give a summary of what transpired at the meeting with the tribe. The Administrator will then update the other members of the Commission.

SLR the construction company that is contracted thru PLIA (The Pollution Liability Insurance Agency) just finished the drilling on two new wells at the Illahee store sight.

The DNR (Department of Natural Resources) visited the Port of Illahee on Tuesday, July 18, 2023 they are looking into renewing the aquatic lease agreement with the Port. Cailan from the (DNR) came to the Port and walked the Property with Commissioner Aho. At one point she looked up at the lights on the dock and asked if they were going to stay? There was much discussion amongst the Commissioners about the squid fishermen being upset if they did not have lights. Historically the Port has hosted squid fisherman for a long time, no lights would be a big deal. Commissioner Buesch had an idea of relocating the lights to the gangway, the lights would shine up rather than down from up above. The DNR requested more information from John Piccone (Sound West Engineering) about the renewal of the lease

Waterfront Improvement Project (Upland Improvements)

Commissioner Aho reported that all permits are behind schedule and we are still waiting for an answer from the county.

Pier Piling Repair;

BFP Grant application for piling replacement/other funding

Commissioner Aho informed the Commission about a phone call that John Piccone had with Henry at the RCO (Recreation and Conservation Office). Henry asked what the status of the Ports lease agreement with the DNR is? During that same conversation John asked Henry what the status of the BFP grant application was? Henry responded that the grant application will be processed soon.

Store Site Renovation:



Commissioner Buesch met with Dave Ghylin from Daves Septic Design and Dara with the Kitsap Public Health Department. Dave thinks he will be able to use the existing drain field site but has to wait for the Kitsap Public Health Departments approval to start his testing. Roy Barton asked if there are no problems with using the existing drain field site then you won't have to use the vacant lot for the drain- field, could you sell it ? Commissioner Buesch Responded that Dave said to hang on to the lot just in case. When Commissioner Aho met with Dave last year he asked what would happen if someone wanted to use milk products or possible grease would you need to do anything different? Dave explained, that's when you need a separate holding tank, you do not want to put that material directly in to the drain-field. You would need to have a reserve drain-field. Commissioner Buesch responded that Dave discussed that possibility with him and that if the current drain- field or design is not acceptable, there is enough room north of the store to have a reserve drain-field. They would insert a snake with a camera on the end to determine if they need a reserve drain -field or not .

Reports

Treasurer's Report as of July31, 2023 General Fund \$107571.26 Investments \$ 284,354.19
Good Property Management (GPM) Account \$199.00 (total: \$392, 124.45)

State Audit

Commissioner Rupert submitted Resolution No. 2023-04 Credit Card Agreement. Commissioner Aho asked what RCW the Credit Card Agreement/ Resolution is in reference to? It was then discussed that Commissioner Rupert is going to submit the Resolution at the next Port meeting with the RCW it is in reference to. *Motion made by Commissioner Rupert to table Resolution No. 2023-04 (motion by Rupert ; second by Buesch all in favor)*

Properties-

5560 Oceanview Blvd-

Nothing to report.

5500 Illahee Road- Illahee Road-

Nothing to report.

5507 Illahee Road / Illahee Store Property

There was a conversation regarding the presence of a van parked at the Illahee store for a few days in July. Eventually, the van left the premises after the Commissioners, along with several community members, approached them at different times and requested their departure. During the discussion, a member of the Illahee community mentioned a mobile application called "See Click Fix." This app can be downloaded to your phone and serves as a convenient tool for receiving, tracking, and responding to service requests made by citizens within the community

Dock/Pier

Nothing new to report.



New Business

1. Legislative Changes RCW 42.30.230

Physical meeting location required

The Administrator talked about the training she took through the MRSC (Municipal Research Service Center) regarding Legislative Changes in 2022. One of the main topics that was discussed in the training was that all Public Ports need to have a in person public meeting place.

2. Resolution 2023-4

Interim Public Meeting Policy

Resolution 2023-4 was discussed amongst the Commissioners about possibilities of having the zoom meetings at The Port of Silverdale. Commissioner Aho would like to see if the Illahee Store would be available in a few months. *Motion made to table Resolution 2023-4 (motion by Rupert ; second by Buesch all in favor).*

3. Illahee Day's

There was much discussion about having Illahee days at the Illahee Store, a few of the items that were discussed was what supplies are needed, what food is needed, and what Commissioner was going to be in charge of planning Illahee days. It was decided amongst the Commission that Commissioner Rupert is going to handle the planning part of Illahee Days and will post about the event on the Facebook Community Page and the Kiosk in front of the Illahee Store. It was decided amongst the Commissioners that Illahee Days is going to be on September 9 , 2023 any left- over food will be donated to the local food banks. *Commissioner Aho made a motion to approve Illahee Day's giving Commissioner Rupert a \$1,000.00 budget to work with (motion by Aho; second by Rupert all in favor).*



ADJOURN

At 8:00 PM the meeting adjourned (motion by Aho; second by Rupert all in favor).

Next regular meeting September 13, 2023 @6:30pm- via Zoom

Kitsap All Ports October 30, 2023 @6:30pm

Commissioner

Commissioner

Commissioner

DRAFT



VOUCHER APPROVAL

We, the undersigned Board of Commissioners of the Port of Ilwaco, Kitsap County, Washington, do hereby certify that the merchandise and/or services hereinafter specified have been received and that the vouchers listed below are approved for payment in the amount of \$25,746.25 and from the General Fund, this 9th day of August 2023

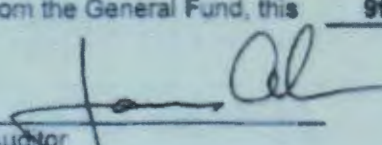

Port Auditor



Port Commissioner



Port Commissioner

Number	Name	Amount
5063	JAMES AHO	256.00
5064	JEFFREY S. RUPERT	384.00
5065	JONATHAN BUESCH	256.00
5066	BANK OF AMERICA	17.03
5067	CASCADE NATURAL GAS	5.00
5068	ENDURIS	18,771.00
5069	HONEY BUCKET	135.50
5070	NORTH PERRY AVENUE WATER DISTRICT	163.57
5071	PORT OF SILVERDALE	750.00
5072	PUGET SOUND ENERGY	86.60
5073	SOUNDWEST ENGINEERING ASSOCIATES	3,388.50
5074	US BANK	200.00
5075	WASHINGTON STATE DEPARTMENT OF REVENUE	1,211.86
5076	WASTE MANAGEMENT	121.19

Kitsap All Ports Association
July 31, 2023
Meeting Minutes

The meeting was held in the Brownsville Yacht Club and via zoom.
The meeting was called to order at 6:30 By Caleb Reese from the Port of Silverdale.

In attendance were Greg Englin, James Strode, Lary Coppola, Robyn Dally, James Weaver, Caleb Reese, Douglas Kitchens, Ed Scholfield, Steve Heacock, Tom Rose, Eugene Madayag, Jennifer Olson, Joseph DaBell; From the WPPA: Eric Ffitch, Tasha Cilurso, Carly Michiels and Mandy Lill

In attendance on Zoom were Robert Ballard and Jeff Rupert

The Pledge of Allegiance initiated the meeting.

Introductions were provided for the attendees and for those on zoom.

After Introductions, Eric Ffitch with the WPPA (**Washinton Public Ports Association**) introduced himself to the group and gave bio on himself and his staff who was also there. Tasha Cilurso, Carly Michiels and Mandy Lill. Eric said the best way to help the Ports is to learn from other Ports and bring them together to share their experiences. He also mentioned he would invite the new CEO with PNWA (Pacific Northwest Waterways Association) to the small Port's convention, although they advocate for federal policies. While WPPA advocates for state policies and trying to work together for a common ground.

Port of Allyn

The Port of Allyn gave an update on the sealion invasion that destroyed a two-year-old dock, power peds, and pump out . They are having a difficult time getting contractors to bid on the project. They are also working with lobbyist to receive federal money to rebuild their dock.

Port of Manchester

The Port of Manchester got their cameras installed, they are also looking into redoing their resolution with the Kitsap County Sheriff's department. The Port recently called law enforcement about kids in the Port parking lot doing donuts and not abiding by the rules. The Sheriff's department cannot arrest them or enforce them to leave.

Port of Kingston

The Port of Kingston is 20% along with the design of their hotel project.
The County is going through the Comp Plan to increase height limit to 55 feet.
They are looking at all sources of funding from public sector, to private sector to present all options to the Commissioners. They also mentioned that the Port parking lot revenues is pretty close to pre-covid numbers.

Port of Bremerton

The Port of Bremerton reported that after two years NMIS has accepted their mitigation credits. They have more credits to buy, but they can move forward with the Port Orchard breakwater. The Port has support from the community with letters from the Sheriff, Fire District and the

Tribe. They inherited parking from the city of Port Orchard and need to update/rewrite the current ILA. Guest moorage with the Port is at 98 percent capacity. The Cruise ship is not a money maker but the Port is thinking it will boost tourism and be beneficial for the Port and the community.

Port of Poulsbo

The Port of Poulsbo reported that they are on the home stretch with their breakwater. Carol sat with the Suquamish tribe to work out the details. The tribe had a blessing ceremony at the Port of Poulsbo for the new breakwater. The Port also mentioned that they are short staffed.

Port of Silverdale

The Port of Silverdale reported that they chose American Construction Company for their dredging project. There is not electrical on the pier or floats they had an electrical fire/ shortage and the whole electrical system needs to be replaced because they cannot get an electrical permit unless it is up to code.

Port of Brownsville

The Port of Brownsville talked about their current derelict tug that refuses to pay moorage and is putting the 28 people who have homes in the marina in jeopardy of losing their home. The Port also discussed setting up a derelict vessel group in the Kitsap Peninsula so Ports can stay informed and we can help each other out.

The next Kitsap County All-Ports meeting date was identified as Monday, October 30, 2023, at 6:30 pm.

The meeting was adjourned at 8:35 p.m.
Jennfer Olson, Port of Silverdale– Recorder

Commissioner

PORT OF ILLAHEE PUBLIC PIER & FLOAT REHABILITATION

SHEET INDEX	
1	COVER, VICINITY MAP
2	EXISTING CONDITIONS & DEMOLITION PLAN
3	PROPOSED SITE PLAN
4	GANGWAY AND FLOAT SECTIONS A
5	GANGWAY AND FLOAT SECTIONS B & C
6	TYPICAL FLOAT DETAILS

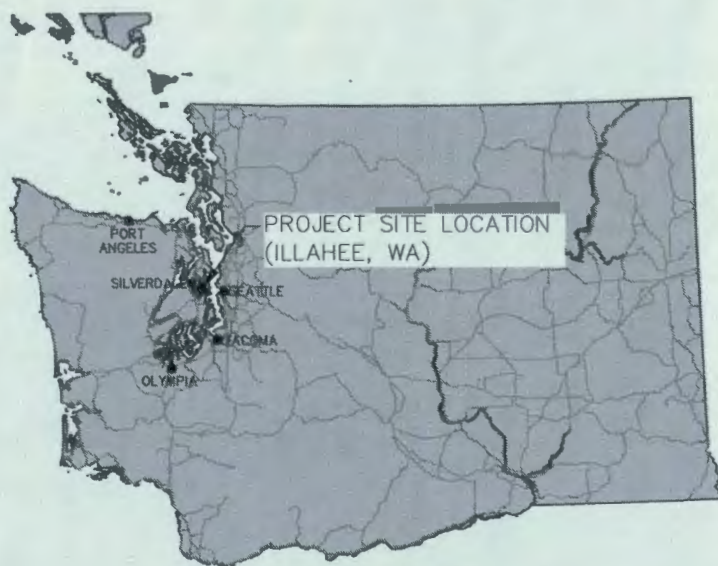

**WASHINGTON
KEY MAP**

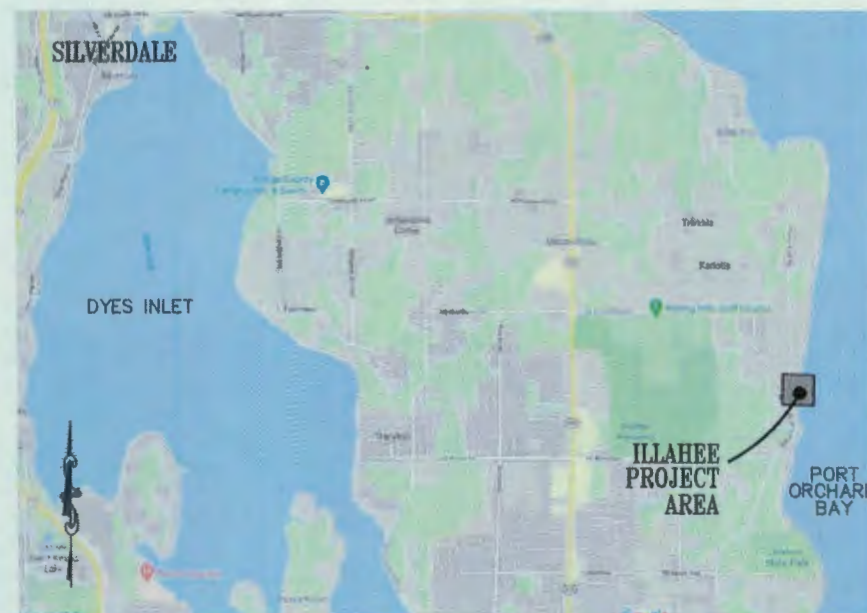

PURPOSE: REPLACEMENT OF FLOATING DOCKS; PIER REMOVAL; AND WATERFRONT ACCESS IMPROVEMENTS

DATUM: MLLW

ADJACENT PROPERTY OWNERS:

1. BURTON JOHN C; PARCEL NO. 4429-001-010-0001
2. KNIGHT LEONARD J; PARCEL NO. 4429-002-001-0000

**PORT OF ILLAHEE
PUBLIC PIER AND DOCK
REHABILITATION PROJECT**

COVER, VICINITY MAP

APPLICATION BY:
PORT OF ILLAHEE

PROPOSED: REPLACEMENT OF FLOATING DOCKS; PIER REMOVAL; AND WATERFRONT ACCESS IMPROVEMENTS

IN: ILLAHEE, WA
AT: PORT ORCHARD BAY
COUNTY: KITSAP COUNTY

SHEET 1 OF 6

DATE: REV 9/8/23

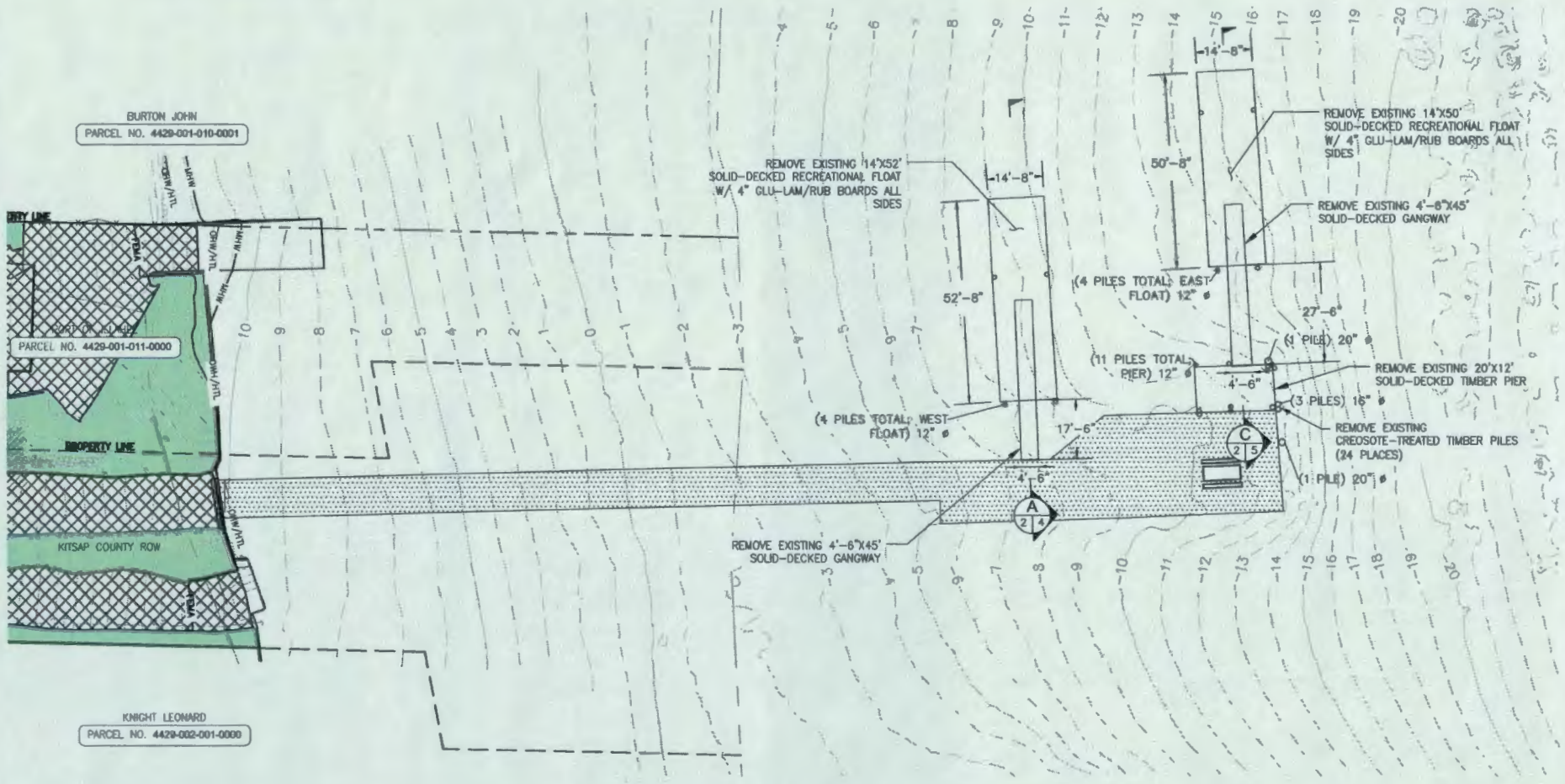

EXISTING CONDITIONS & DEMOLITION

SITE PLAN

SCALE IN FEET

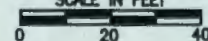

TIDAL WATER LEVELS

HIGH TIDE LINE (HTL)	+11.8'
MEAN HIGH WATER (MHW)	+10.86'
MEAN LOWER LOW WATER (MLLW)	0.0'

PURPOSE: REPLACEMENT OF FLOATING DOCKS; PIER REMOVAL; AND WATERFRONT ACCESS IMPROVEMENTS

DATUM: MLLW

ADJACENT PROPERTY OWNERS:

- BURTON JOHN C; PARCEL NO. 4429-001-010-0001
- KNIGHT LEONARD J; PARCEL NO. 4429-002-001-0000

**PORT OF ILLAHEE
PUBLIC PIER AND DOCK
REHABILITATION PROJECT**

**EXISTING CONDITIONS &
DEMOLITION SITE PLAN**

APPLICATION BY:
PORT OF ILLAHEE

PROPOSED: REPLACEMENT OF FLOATING DOCKS; PIER REMOVAL; AND WATERFRONT ACCESS IMPROVEMENTS

IN: ILLAHEE, WA
AT: PORT ORCHARD BAY
COUNTY: KITSAP COUNTY

SHEET 2 OF 6

DATE: REV 9/8/23

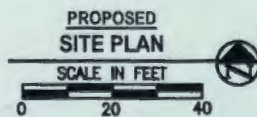
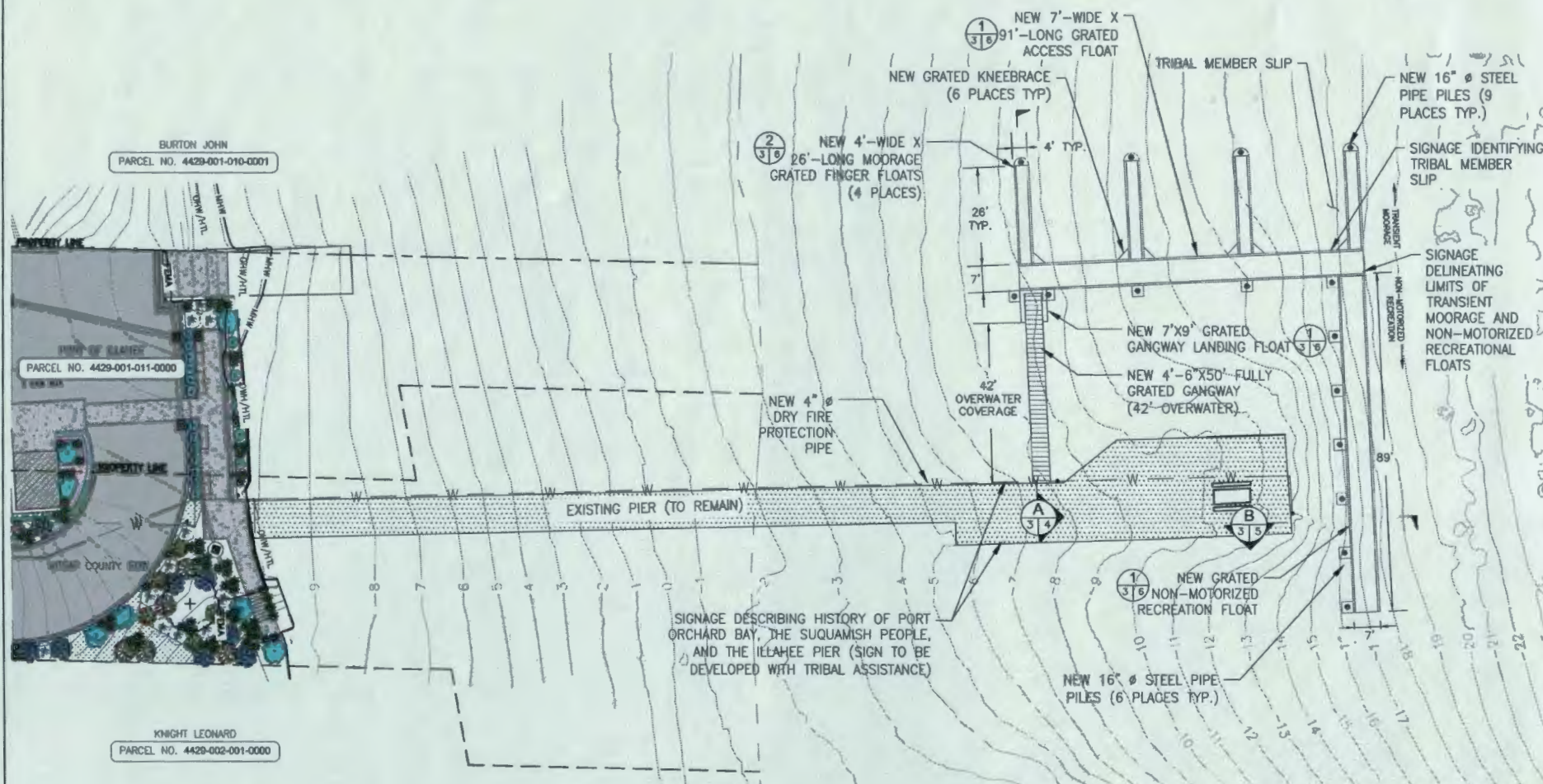

TIDAL WATER LEVELS	
HIGH TIDE LINE (HTL)	+11.8'
MEAN HIGH WATER (MHW)	+10.86'
MEAN LOWER LOW WATER (MLLW)	0.0'

PURPOSE: REPLACEMENT OF FLOATING DOCKS; PIER REMOVAL; AND WATERFRONT ACCESS IMPROVEMENTS

DATUM: MLLW

ADJACENT PROPERTY OWNERS:

- BURTON JOHN C; PARCEL NO. 4429-001-010-0001
- KNIGHT LEONARD J; PARCEL NO. 4429-002-001-0000

**PORT OF ILLAHEE
PUBLIC PIER AND DOCK
REHABILITATION PROJECT**

**PROPOSED
SITE PLAN**

APPLICATION BY:
PORT OF ILLAHEE

PROPOSED: REPLACEMENT OF FLOATING DOCKS; PIER REMOVAL; AND WATERFRONT ACCESS IMPROVEMENTS

IN: ILLAHEE, WA
AT: PORT ORCHARD BAY
COUNTY: KITSAP COUNTY

SHEET 3 OF 6

DATE: REV 9/8/23

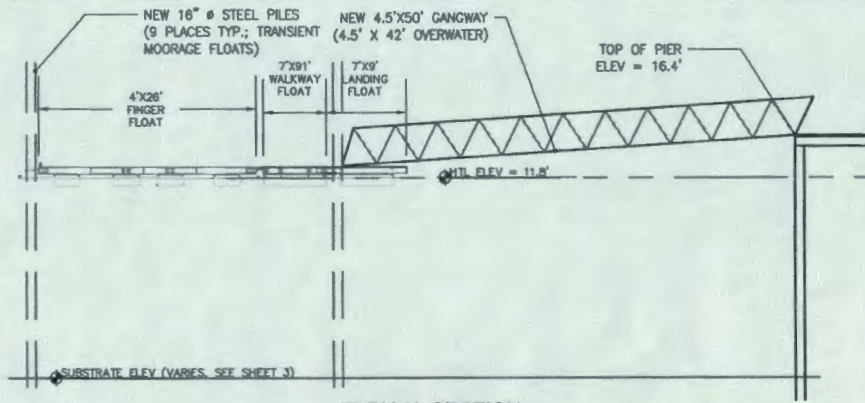

TYPICAL SECTION PROPOSED
 TRANSIENT MOORAGE FLOATS & GANGWAY AT HTL = 11.8'
 SCALE IN FEET

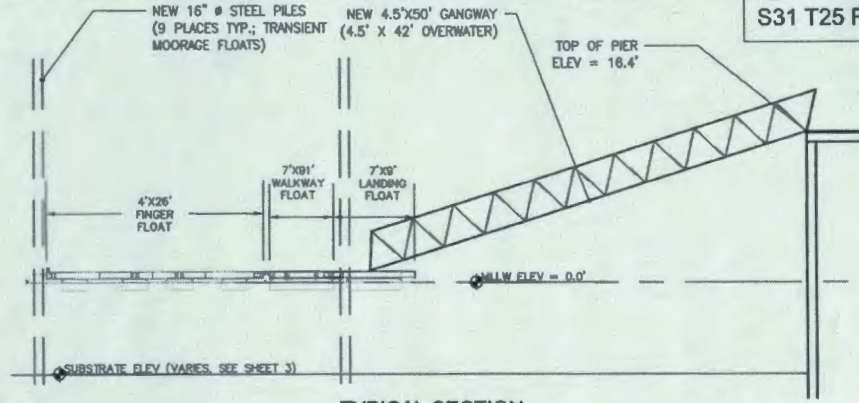

TYPICAL SECTION PROPOSED
 TRANSIENT MOORAGE FLOATS & GANGWAY AT MLLW = 0.0'
 SCALE IN FEET

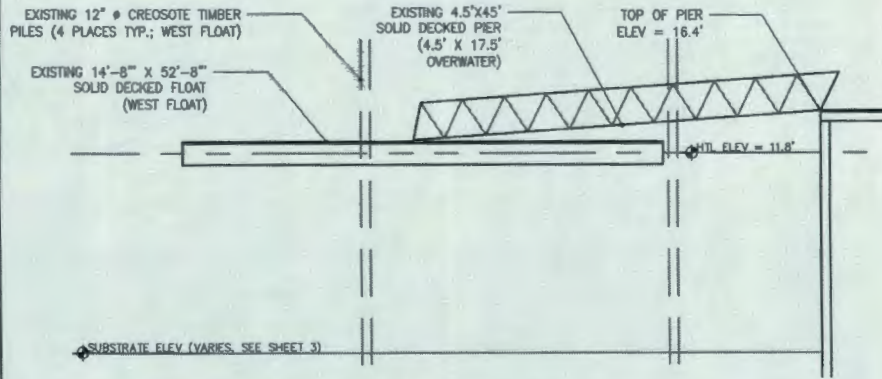

TYPICAL SECTION EXISTING W. FLOAT
 FLOATS & GANGWAY AT HTL = 11.8'
 SCALE IN FEET

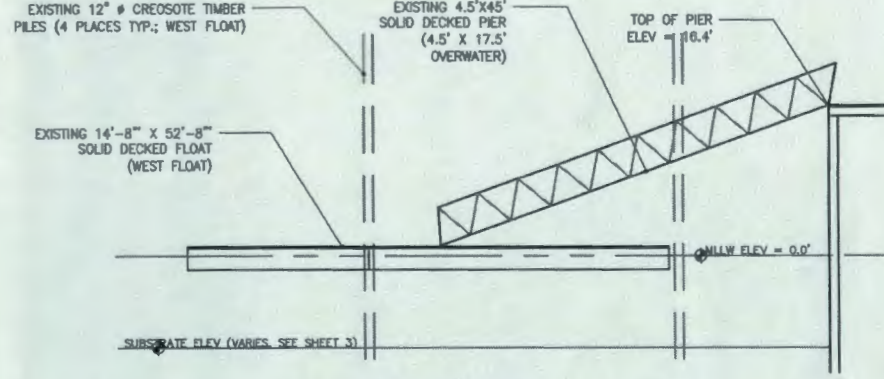

TYPICAL SECTION EXISTING - W. FLOAT
 FLOATS & GANGWAY AT MLLW = 0.0'
 SCALE IN FEET

TIDAL WATER LEVELS

HIGH TIDE LINE (HTL)	+11.8'
MEAN HIGH WATER (MHHW)	+10.86'
MEAN LOWER LOW WATER (MLLW)	0.0'

PURPOSE: REPLACEMENT OF FLOATING DOCKS; PIER REMOVAL; AND WATERFRONT ACCESS IMPROVEMENTS

DATUM: MLLW

ADJACENT PROPERTY OWNERS:

- BURTON JOHN C; PARCEL NO. 4429-001-010-0001
- KNIGHT LEONARD J; PARCEL NO. 4429-002-001-0000

**PORT OF ILLAHEE
 PUBLIC PIER AND DOCK
 REHABILITATION PROJECT**

**GANGWAY & FLOAT
 CROSS SECTIONS A**

APPLICATION BY:
 PORT OF ILLAHEE

PROPOSED: REPLACEMENT OF FLOATING DOCKS; PIER REMOVAL; AND WATERFRONT ACCESS IMPROVEMENTS

IN: ILLAHEE, WA
AT: PORT ORCHARD BAY
COUNTY: KITSAP COUNTY

SHEET 4 OF 6

DATE: REV 9/8/23

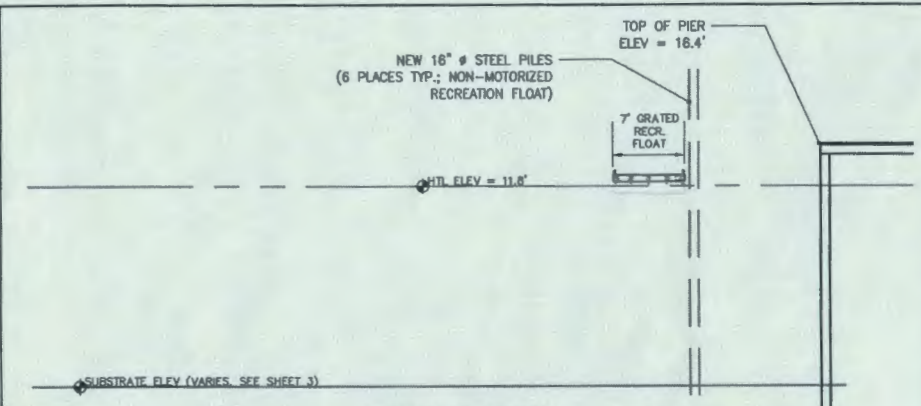

TYPICAL SECTION PROPOSED
 NON-MOTORIZED RECREATION FLOAT & GANGWAY AT HTL = 11.8'
 SCALE IN FEET

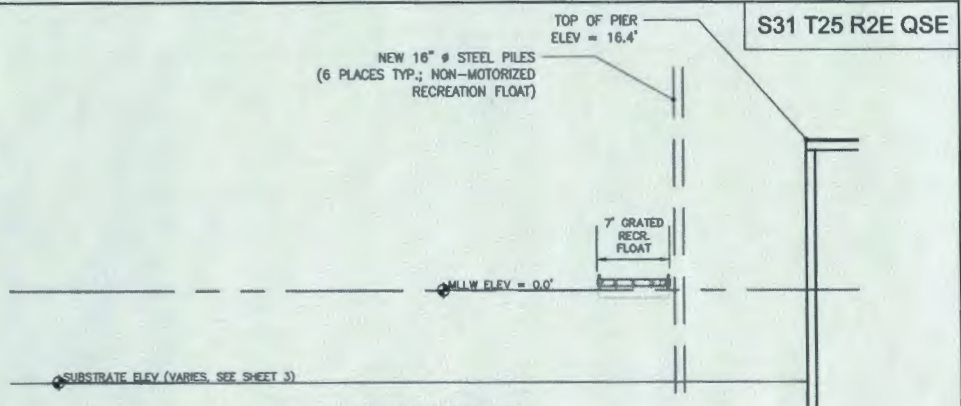

TYPICAL SECTION PROPOSED
 NON-MOTORIZED RECREATION FLOAT & GANGWAY AT MLLW = 0.0'
 SCALE IN FEET

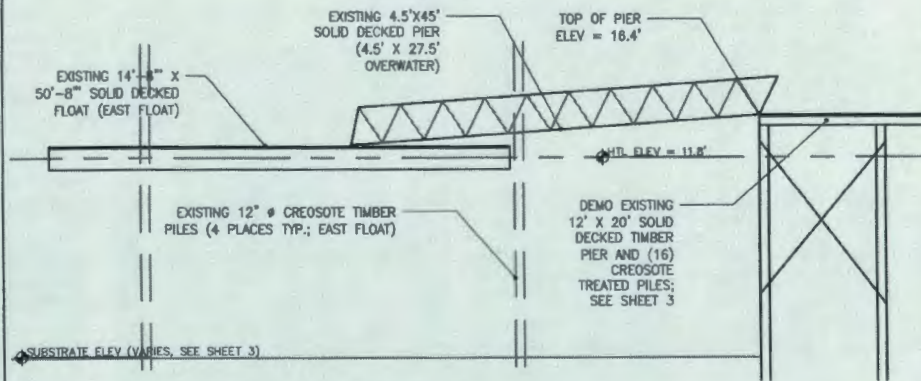

TYPICAL SECTION EXISTING E. FLOAT
 FLOATS & GANGWAY AT HTL = 11.8'
 SCALE IN FEET

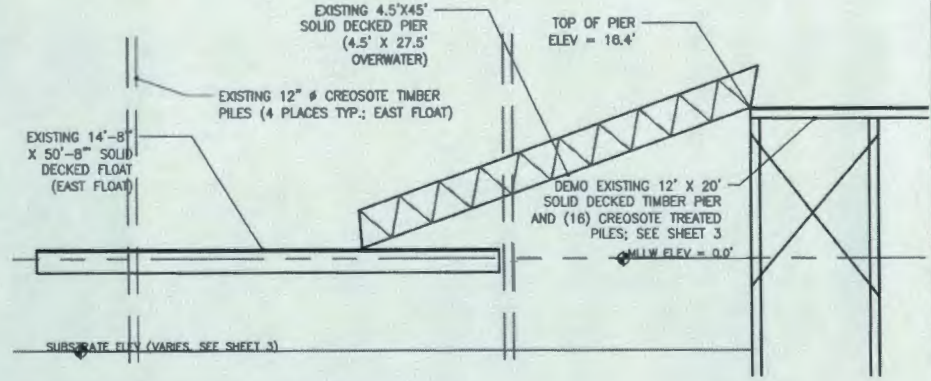

TYPICAL SECTION EXISTING - E. FLOAT
 FLOATS & GANGWAY AT MLLW = 0.0'
 SCALE IN FEET

TIDAL WATER LEVELS	
HIGH TIDE LINE (HTL)	+11.8'
MEAN HIGH WATER (MHW)	+10.86'
MEAN LOWER LOW WATER (MLLW)	0.0'

PURPOSE: REPLACEMENT OF FLOATING DOCKS; PIER REMOVAL; AND WATERFRONT ACCESS IMPROVEMENTS

DATUM: MLLW

ADJACENT PROPERTY OWNERS:

- BURTON JOHN C; PARCEL NO. 4429-001-010-0001
- KNIGHT LEONARD J; PARCEL NO. 4429-002-001-0000

**PORT OF ILLAHEE
 PUBLIC PIER AND DOCK
 REHABILITATION PROJECT**

**GANGWAY & FLOAT
 CROSS SECTIONS B & C**

APPLICATION BY:
 PORT OF ILLAHEE

PROPOSED: REPLACEMENT OF FLOATING DOCKS; PIER REMOVAL; AND WATERFRONT ACCESS IMPROVEMENTS

IN: ILLAHEE, WA

AT: PORT ORCHARD BAY

COUNTY: KITSAP COUNTY

SHEET 5 OF 6 **DATE:** REV 9/8/23

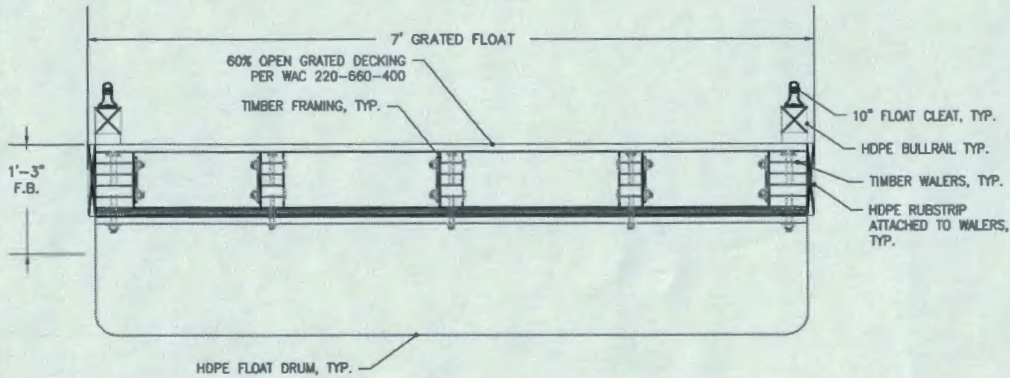

1 7' FLOAT TYPICAL DETAIL
N.T.S.

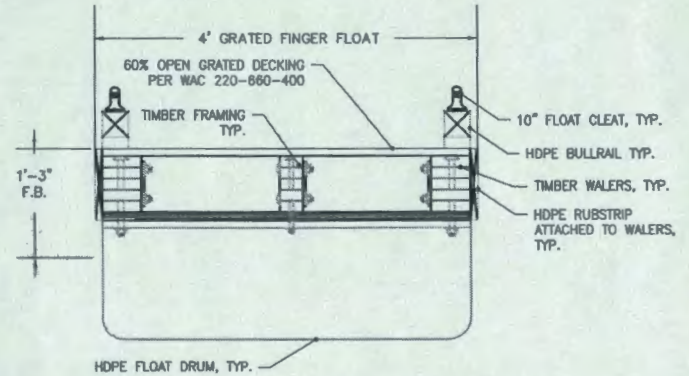

2 FINGER FLOAT TYPICAL DETAIL
N.T.S.

TIDAL WATER LEVELS

HIGH TIDE LINE (HTL)	+11.8'
MEAN HIGH WATER (MHW)	+10.86'
MEAN LOWER LOW WATER (MLLW)	0.0'

PURPOSE: REPLACEMENT OF FLOATING DOCKS; PIER REMOVAL; AND WATERFRONT ACCESS IMPROVEMENTS

DATUM: MLLW

ADJACENT PROPERTY OWNERS:

- BURTON JOHN C; PARCEL NO. 4429-001-010-0001
- KNIGHT LEONARD J; PARCEL NO. 4429-002-001-0000

**PORT OF ILLAHEE
PUBLIC PIER AND DOCK
REHABILITATION PROJECT**

**TYPICAL FLOAT
DETAILS**

APPLICATION BY:
PORT OF ILLAHEE

PROPOSED: REPLACEMENT OF FLOATING DOCKS; PIER REMOVAL; AND WATERFRONT ACCESS IMPROVEMENTS

IN: ILLAHEE, WA

AT: PORT ORCHARD BAY

COUNTY: KITSAP COUNTY

SHEET 6 OF 6

DATE: REV 9/8/23

PORT OF ILLAHEE

2023 BUDGET REVIEW AS OF September 1, 2023

					BUDGETED	ACTUAL		
TOTAL ESTIMATED BEGINNING BALANCE					390,941.38	371,321.61		
REVENUES:								
670.00	NonRevenues - Loan Contingency for Improvement Projects				700,000.00	0.00		
693.00	Operating Grants Reimbursement ALEA & BFP				1,230,563.00	15,195.73		
695.00	Real Property Rentals				30,000.00	28,400.00	94.67%	
699.10	Investment Interest				800.00	4,909.02	613.63%	
699.20	Property Tax				94,500.00	51,246.76	54.23%	
EXPENDITURES:								
721.00 MARINA OPERATING								
721.80	Utilities				\$3,000.00	1,639.49	-54.65%	water; power, sewer @ facilities
721.90	Other				\$500.00	130.00	-26.00%	SSWM taxes & misc. on facility properties
723.00 MARINA MAINTENANCE								
723.30	Outside Services				\$2,500.00	480.21	-19.21%	general maintenance, landscaping at dock facility
723.40	Supplies				\$1,000.00	0.00	0.00%	Supplies for maintenance
723.90	Other: Piling Replacement				\$145,000.00	2,337.50	-1.61%	Piling Replacement Project
761.00 PROPERTY LEASE/RENTAL								
761.30	Outside Servies				\$3,000.00	8,800.05	-293.34%	Property Management GPM's 10% fee
763.00 PROPERTY LEASE/RENTAL MAINTENANCE								
763.40	Supplies				\$500.00	0.00	0.00%	supplies for maintenance at properites
763.60	Facility Maintenance				\$2,000.00	225.00	-11.25%	maintenance - roof cleaning/ furnace service
763.70	General and Administrative				\$500.00	500.62	-100.12%	SSWM taxes & misc. on rental properties
763.80	Utilities				\$1,500.00	1,341.58	-89.44%	Utilities @ rental properties
763.90	Other				\$4,000.00	3,792.70	-94.82%	Leasehold Excise Tax
771.00 DEBT REDEMPTION								
771.50	Other Note/Contracts				\$10,000.00	5,000.00	-50.00%	Principal to be paid on Ocean View bond; principal payments on 2nd bond not
773.00 FIXED ASSET DISBURSEMENT								
773.50	Property Improvements: 5507 Illahee Road				\$350,000.00	0.00	0.00%	improvements to the Illahee Store property - clean up, permits, design, constr
773.90	Other Property Improvements				\$5,000.00	0.00	0.00%	In case problems arise on the other Port owned properties (roofs, foundations,
774.00 WATERFRONT								
774.40	Waterfront Access Improvements: Upland Work				\$724,434.00	7,228.75	-1.00%	Remaining ALEA \$812,000 (RCO 500,000/Port 312,000)
774.40	Waterfront Access Improvements: Marina Work				\$1,060,092.00	56,255.00	-5.31%	Remaining BFP \$1,150,065 (RCO 851,065/Port 299,000)
780.00 GENERAL AND ADMINISTRATIVE								
781.10	Commissioner compensation				\$12,800.00	7,168.00	-56.00%	Commissioners stipends - (\$128) per Commissioner per month added additiona
781.20	Commissioner reimbursement				\$1,500.00	0.00	0.00%	travel expense/mileage
781.30	Outside services				\$20,000.00	6,282.91	-31.41%	legal, administrative
781.40	Supplies				\$200.00	0.00	0.00%	Office supplies
781.60	Facility rentals				\$400.00	0.00	0.00%	??
781.70	G&A Operations				\$25,000.00	23,545.77	-94.18%	Insurance, annual dues, promotional hosting, audit
789.10	Economic development				\$2,500.00		0.00%	Community Involvement
799.90 NON-OPERATING EXPENSE								
799.91	Interest Expense				\$5,000.00	1,956.40	-39.13%	Interest to be paid on Ocean View bond; Interest on 2nd bond not due until 20
799.92	Election Expense				\$5,000.00		0.00%	Position #1 & Position #2 on November ballot
BALANCE AS OF :						\$344,389.14		

NEW
OVER

**PORT OF ILLAHEE
2023 FINAL BUDGET**

	DETAIL	TOTALS
TOTAL ESTIMATED BEGINNING BALANCE		377,000.00
REVENUES:		
670.00 NonRevenues - Loan Contingency for Improvement Projects	700,000.00	
693.00 Operating Grants Reimbursement ALEA & BFP	1,230,563.00	
695.00 Real Property Rentals	30,000.00	
699.10 Investment Interest	800.00	
699.20 Property Tax	94,500.00	
TOTAL ESTIMATED REVENUES:		2,055,863.00
TOTAL ESTIMATED FUNDS AVAILABLE:		2,432,863.00
EXPENDITURES:		
721.00 MARINA OPERATING		
721.80 Utilities	3,000.00	
721.90 Other	500.00	
723.00 MARINA MAINTENANCE		
723.30 Outside Services	2,500.00	
723.40 Supplies	1,000.00	
723.90 Other: Piling Replacement	145,000.00	
761.00 PROPERTY LEASE/RENTAL		
761.30 Outside Services	3,000.00	
763.00 PROPERTY LEASE/RENTAL MAINTENANCE		
763.40 Supplies	500.00	
763.60 Facility Maintenance	2,000.00	
763.70 General and Administrative	500.00	
763.80 Utilities	1,500.00	
763.90 Other	4,000.00	
771.00 DEBT REDEMPTION		
771.50 Other: Note/Contracts	10,000.00	
773.00 FIXED ASSET DISBURSEMENT		
773.50 Property Improvements	350,000.00	
773.90 Other: Property Improvements	5,000.00	
774.00 WATERFRONT FACILITIES		
774.40 Waterfront Access Improvements: Upland Work	724,434.00	
774.40 Waterfront Access Improvements: Marina work	1,060,092.00	
780.00 GENERAL AND ADMINISTRATIVE		
781.10 Commissioner compensation	12,800.00	
781.20 Commissioner reimbursement	1,500.00	
781.30 Outside services	20,000.00	
781.40 Supplies	200.00	
781.60 Facility rentals	400.00	
781.70 G&A Operations	25,000.00	
789.10 Economic development	2,500.00	
790.00 NON-OPERATING EXPENSE		
799.91 Interest Expense	5,000.00	
799.92 Election Expense	5,000.00	
TOTAL ESTIMATED EXPENDITURES:		(2,385,426.00)
TOTAL ESTIMATED ENDING BALANCE:		47,437.00

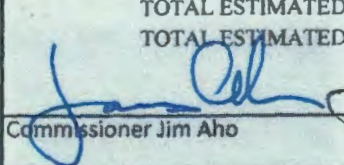
 Commissioner Jim Aho

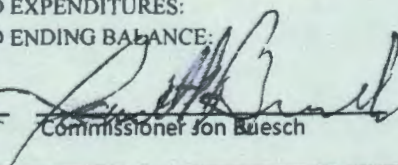
 Commissioner Jon Buesch

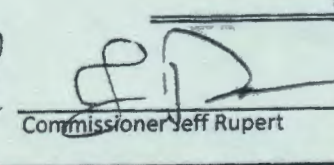
 Commissioner Jeff Rupert